

## Specification Sheet

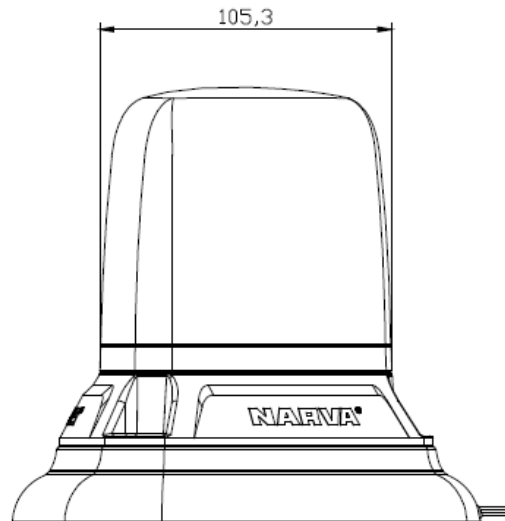

### Technical Specifications:

Height	130mm
Lens Colour	Amber
Output Colour	Amber
Lens Material	Makrolon 2607 Polycarbonate
Housing Material	Polycarbonate
Weight	1.12kg
Input voltage	10-33V
LED's	36 x 1W
Current Draw (rotate, flash)	1A, 1.6A @ 12V
SAE	J845 Class 1, W3-1
ECE R65	TA2 E9 00.6619—Rotate TA1 E9 00.6619—Flash
ECE R10	10R-06.22672
CISPR25	Class 3
ROHS	✓ - LCS210316139AR
REACH	✓ - LCS210316138AR
IP Rating	IP67
Operating Temperature	-30°C — +60°C
Vibration tests	IEC 60068-2-64
Mechanical Shock Test	ISO 16750-3:2007 4.2.2
Night Mode Percentage	60%
Magnet Speed Rating	120 km/h

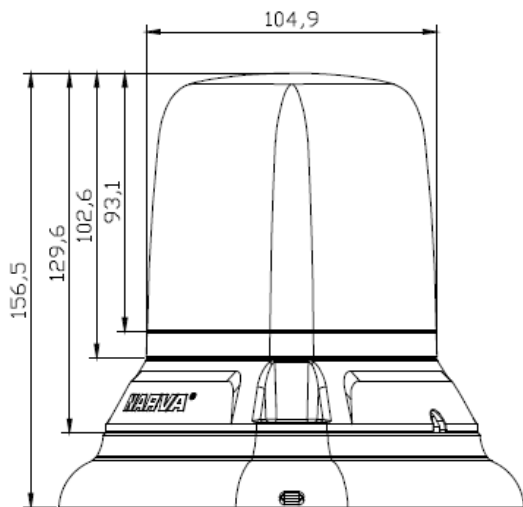
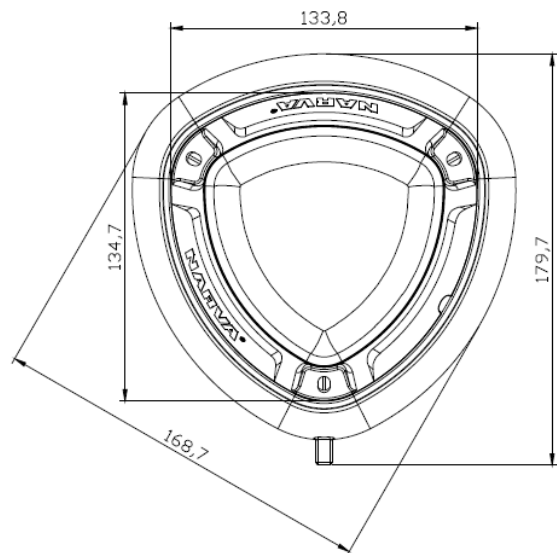

### Wiring Instructions:

Cigarette Lighter Plug with three position switch—Off/On/Pattern change

### Flash Patterns

The unit comes with 4 user-selectable flash patterns plus steady on

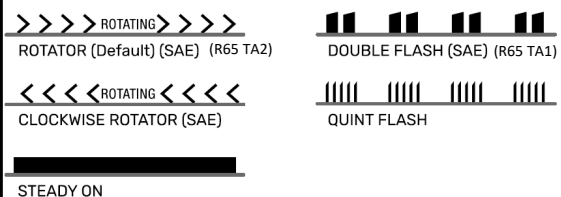

Distributed by Brown and Watson International

1500 Ferntree Gully Road, Knoxfield, 3180

P.) 1800 422 422